

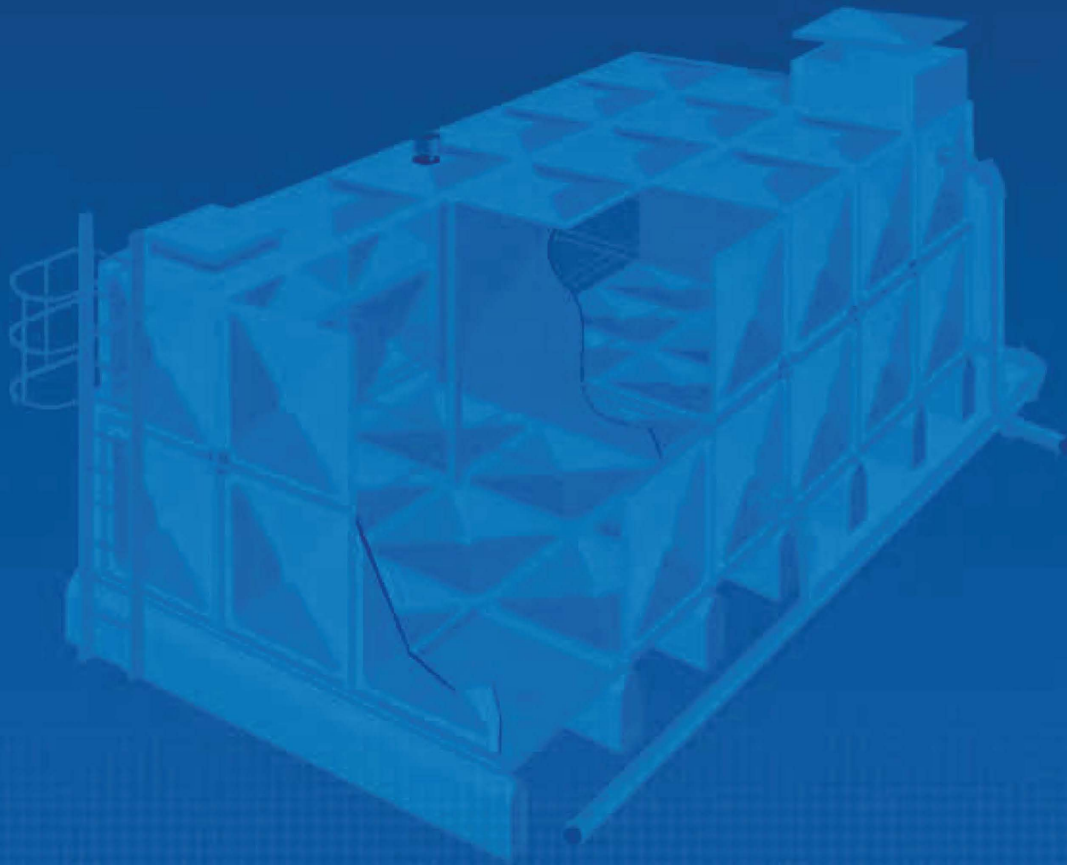

# GRP

## Sectional Storage Tanks



**TABLE OF CONTENTS**

Introduction .....

GRP Sectional Water Storage Tanks (Std & L –Shaped) .....

GRP Totally Internally Flanged Tanks (TIF) & Internally Flanged Tanks (IF) .....

LPCB Approved Fire Protection Tanks .....

Rainwater Harvesting Tanks .....

Site Requirements – Base Requirements .....

Site Requirements – Access Requirements .....

Tank Maintenance .....

**GRP SECTIONAL COLD WATER STORAGE TANKS (STANDARD & L SHAPED)**

Dewey Waters employs two moulding techniques Single Face Contact Moulding (SFCM) and Hot Press Moulding (HPM) to manufacture the sectional panels. The method employed depends on individual site requirements and which technique provides the most economical solution for our clients. Both techniques adhere to current British Standards, are WRAS approved and are covered by our quality control procedures.

The diagram and descriptions below detail the components of our sectional tank system.

*Sectional tanks are supplied in the following formats:*

- Internally flanged base** - Externally flanged sides:  
This tank is suitable for installation on a fully supporting flat base
- Externally flanged base** - Externally flanged sides:  
This type of base allows easy access to bolts for maintenance and tank may be fully drained.
- Internally flanged base** – Internally flanged sides: This tank is used where the space available is restricted.

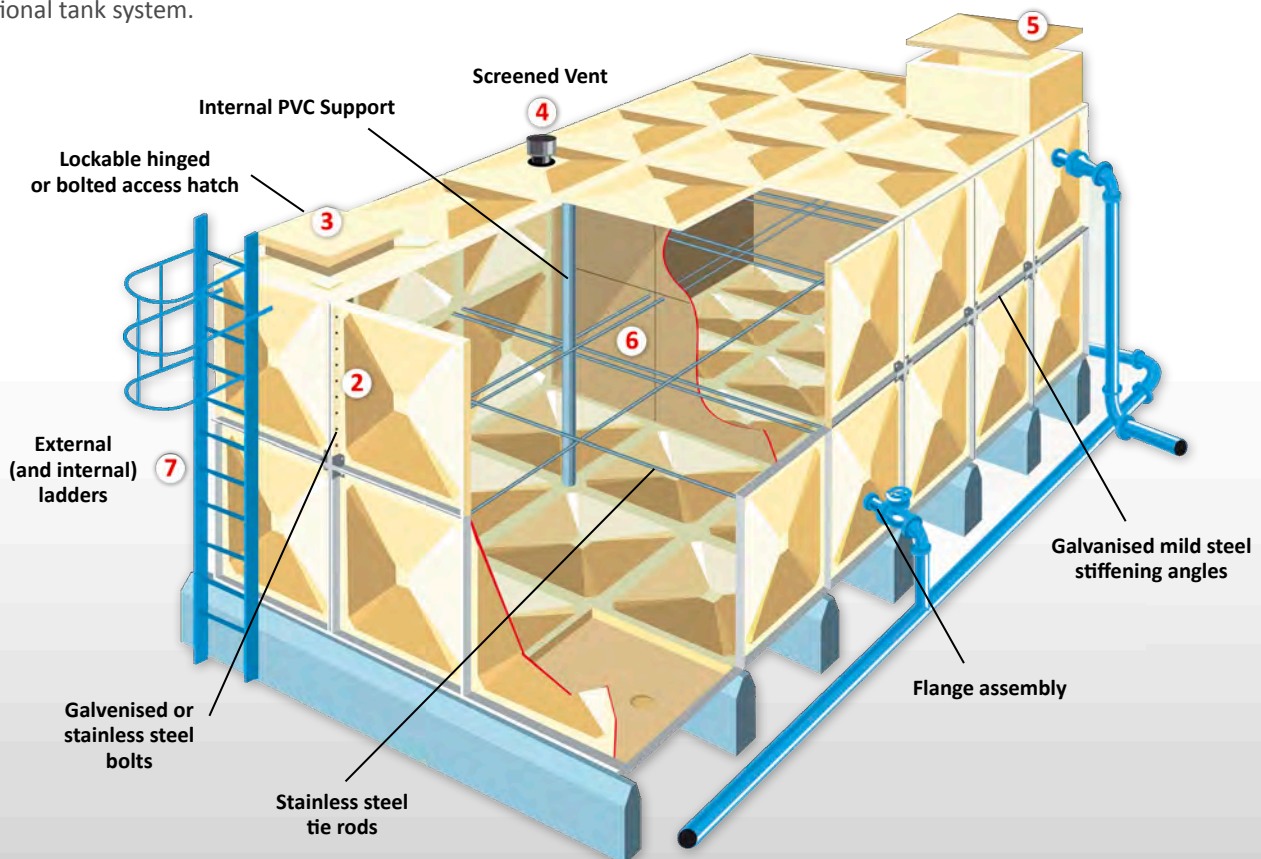



## INTRODUCTION

Dewey Waters Ltd is a market leader in the manufacture of Glass Reinforced Polyester (GRP) products. With over 50 years experience, we have accumulated an in-depth knowledge of the most efficient designs, testing procedures, up to date advances in material technology and various manufacturing techniques.

Operating from our base in Weston - super - Mare, our highly trained staff provides an efficient international service to a variety of clients within different industries. Equipped with the most comprehensive range of GRP products available on the market, our clients can expect to receive an unprecedented unified response which will be provided by our technical, design, sales, manufacturing, service delivery and on site installation team.

We specialise in the design and manufacture of GRP cold water storage tanks. Tanks are fabricated in panel format, delivered and assembled on site. We are confident that with our knowledge and experience, the flexibility of our tank designs will meet the most demanding of site restrictions and specifications. We manufacture the following range of cold water storage tanks

- Standard Sectional Cold Water Storage Tanks
- L Shaped Sectional Cold Water Storage Tanks
- Totally Internally Flanged & Internally Flanged Tanks
- LPCB Approved Sprinkler Tanks for Fire Fighting
- Rainwater Harvesting Tanks to BS8515

## STANDARD COMPONENTS

### 1. Tank

- Insulated, suitable for storage of “wholesome” potable water.
- Un-insulated for storing of water for non-wholesome applications such as process water for factories, rain water harvesting.
- All panels are fabricated to withstand harsh climatic conditions.

### 2. Bolts

Tanks are assembled using 316 grade S/S bolts internally and galvanised bolts externally, complying with current British Standards BSEN 13280:2001. If required, grade 316 S/S bolts may be placed throughout the tank.

### 3. Access Hatch

An access hatch is supplied as standard for tank maintenance and access.

### 4. Screened Vent

We provide a screened vent with all tanks for ventilation.

## ADDITIONAL COMPONENTS

### 5. Raised Float Valve Housing

Permits the float valve to be mounted at a higher level on the tank, therefore increasing the usable volume of water.

### 6. Tank Division

All buildings requiring un-interrupted water supply should install a divider in the tank. The divider allows one side of the tank to be drained down for maintenance, while water supply is maintained from the second segment of the tank.

### 7. Ladders

Where the tank height is greater than 1.5m, an internal and external ladder is recommended.

**8. Condensation Trays:** Available for every size tank if required. Condensation trays are supplied in sections and bonded into a single unit on site. A condensation tray can only be supplied with tanks that have an internally flanged base.

**9. Connections:** Our sales team will discuss various options available.

**10. Side Access Hatch:** A side access hatch is beneficial where height restrictions apply. It also permits access, if in the event of personnel getting into difficulties inside the tank, while carrying out maintenance work.

**TANK PANELS**

Tank panels are available in metric and imperial sizes. Tanks can be constructed up to a height of 4m using metric half and full panels and 2.4m using imperial half and full panels. L Shaped tanks are available in metric format and up to a height of 3m. Metric and imperial panels are available in half panel increments. The support structure of the tank varies depending on the height of the tank manufactured. Therefore, we have divided our tank into two designs based on the bracing structures:

T1 Design: Tanks from 1 to 3m and 1.2 to 2.4m

T2 Design: Tanks from 3.5 to 4m



T1 Tank

**Panel Variants**

Our experience along with architects/designers demands have led our engineering team to design and manufacture a series of panels, to give more flexibility to our clients.

**Base Panels**

**1. Flat**

Suitable for installation on a concrete foundation.

**2. Truncated**

Suitable for installation on elevated supports or beams.

**3. Self Draining**

Suitable for a half span foundation / full span depending on height.

**Lid Panels**

**4. Self Draining**

Weather drained, but with a perimeter suitable to walk on.

**5. Flat**

Suitable for application with height restrictions.

*For detailed specifications, contact our Technical Department or see separate detailed Base Specifications.*

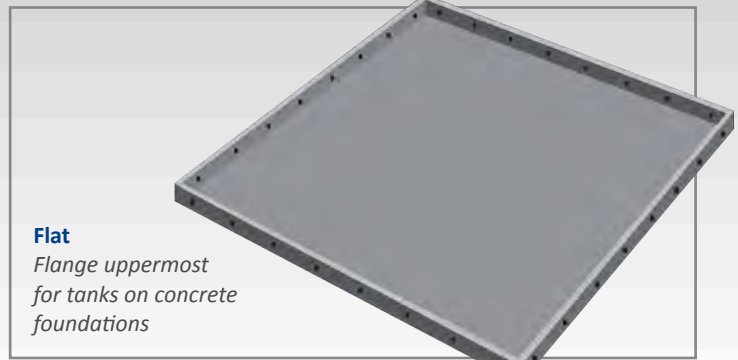

**Flat**  
*Flange uppermost  
for tanks on concrete  
foundations*

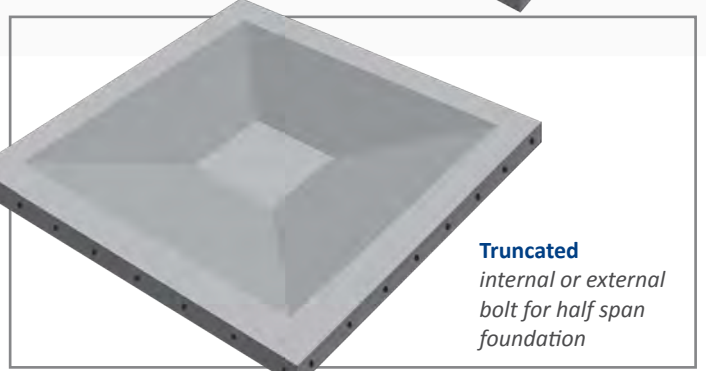

**Truncated**  
*internal or external  
bolt for half span  
foundation*

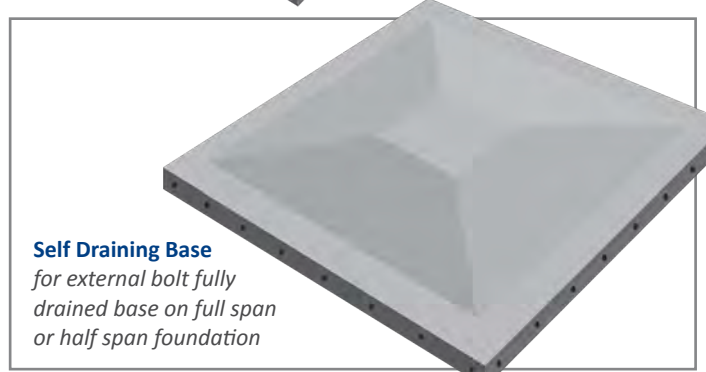

**Self Draining Base**  
*for external bolt fully  
drained base on full span  
or half span foundation*



**Self Draining Lid**  
*weather drained but  
with walking area*

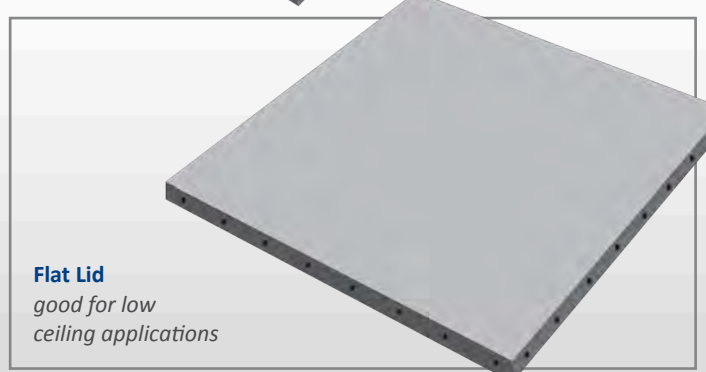

**Flat Lid**  
*good for low  
ceiling applications*

▲ Sample designs from our panel range.

## TIF (TOTALLY INTERNALLY FLANGED) & IF (INTERNALLY FLANGED) TANKS

Where space restrictions apply the Dewey Waters TIF & IF tanks are the best storage option to allow you to maximise storage capacity. Standard access requirements request a clearance of 500mm around the tank for assembly and maintenance purposes. With the Dewey Waters TIF patented design & IF design, these access requirements are reduced. These tanks are designed, so that it is constructed from within, requiring less space for assembly. The tank may be position up against a wall or column, leaving space for other equipment within the plant room.

### Hand Lay Up TIF

All side, base and lid panels are Totally Internally Flanged.

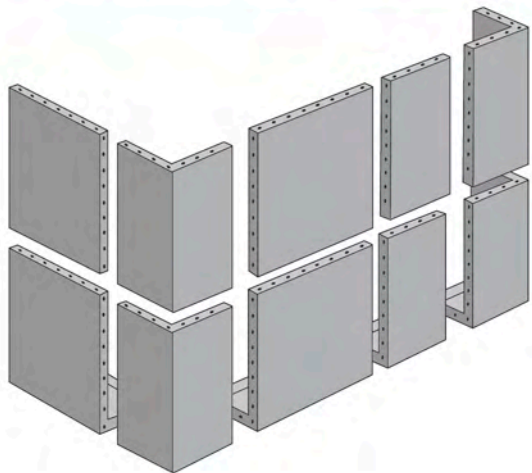
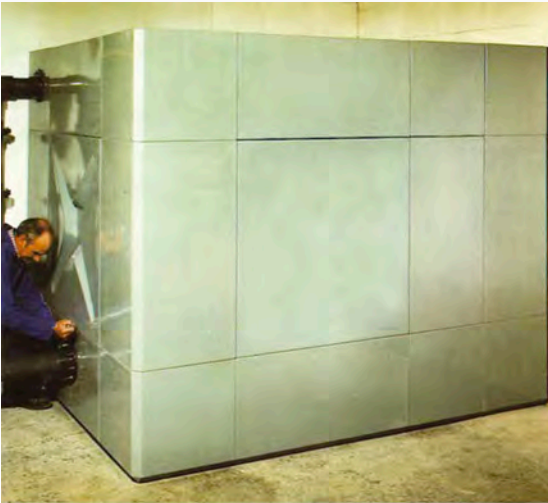

### Hot Press IF

All side, base and lid panels are Totally Internally Flanged, with the only external bolts and flanges around the perimeter edges.

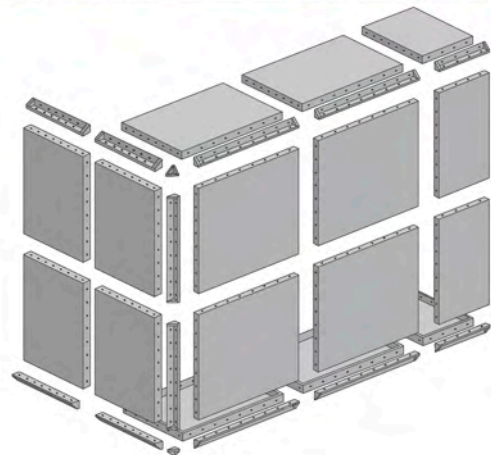
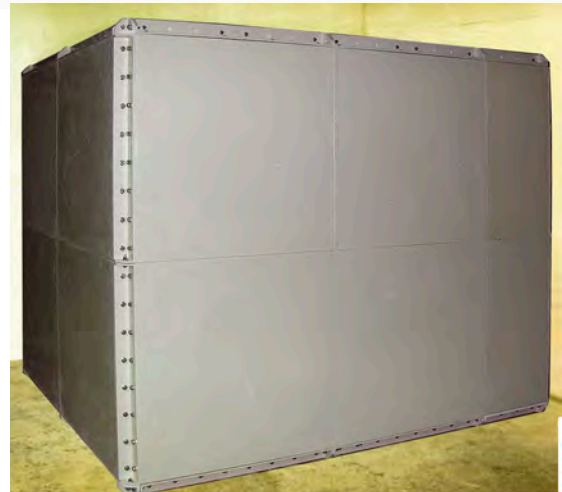

### Hand Lay Up TIF

### Hot Press IF

**All bolts are internal**

Yes

No

**Access to all bolts**

Yes

No

**Space requirements**

50mm

450mm on one side and one end

**Production method**

Hand lay up

Hot press moulded

**Maximum height**

3m

2m

*The TIF is a more versatile and maintenance friendly solution than the Hot Press IF.*

The IF is suitable where there is no restrictive access on two sides. TIF & IF Tanks should only be used when there is no space available to fit a traditional sectional tank. These types of tanks can be built close to walls and in areas with restricted access (as there is no external access to the tanks after assembly, maintenance and rectification of any problems can be difficult or impossible).



## LPCB APPROVED FIRE PROTECTION TANKS

Dewey Waters fire protection tanks are trusted by businesses, municipalities and their insurers who rely on the availability of emergency water supply to a sprinkler system in the event of a fire. We can custom design a fire protection tank according to storage volume and flow requirements. Each tank is engineered to an approved code of practice and configured in accordance with standards & regulations established by the Loss Prevention Certification Board.

Manufactured in sectional format, our fire protection tanks promote economic delivery and allows for fast and easy installation. Panels are fabricated to withstand any weather conditions.

### Tanks are complete with the following components to comply with LPC & British Standards:

- Hydrostatic Contents gauge to measure the level of water in the tank.
- AB Air gap to prevent water siphoning back into the mains water supply.
- Internal Ladder for safe tank access.
- External Aluminium Ladder complete with safety cage to safely gain access to the Man-way cover for maintenance purposes.
- Tank overflow and warning pipes.
- Drainage facility to completely drain down the tank for maintenance work.
- Access Man-way to enable testing, maintenance etc.
- Side Access Hatch.
- Vortex Inhibitor eliminates air circulation through the water when large volumes of water are extracted from the tank, thus increasing the flow level.
- Immersion heater to prevent water from freezing in the tank and pipe work.

### Optional Extras:

- Tank Division to enable constant supply of water when maintenance work is being carried out.
- Hand Railing - space permitting



Automatic sprinkler systems are being increasingly used as part of an informed fire risk assessment process to improve fire safety methods. The new DCSF (Department for Children, Schools & Families) policy on sprinkler systems and their significance against the risk of fire expects that all new schools should have a sprinkler system installed except for low risk schools. Building regulations in England and Wales specify that new residential blocks over 30m high, must be fitted with a sprinkler system. Similarly an un-compartmented area in a shop or self storage building over 2000 sq metres now requires a sprinkler system. In Scotland, all new care homes, sheltered housings, covered shopping centres and high rise residential accommodation above 18 metres high must be fitted with Sprinkler systems.

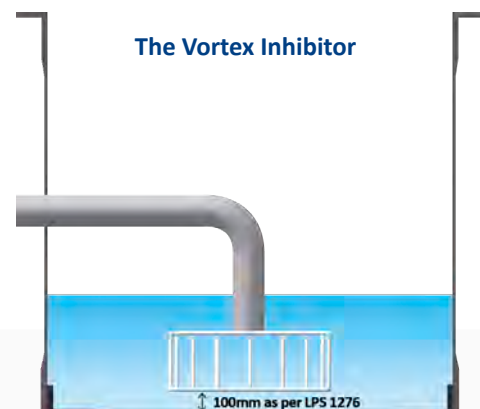

The vortex inhibitor is fitted to the outlet pipe and has a dual purpose within the tank

- Prevents the initiation of vortices when the water is extracted from the tank as liquid is taken from a wider area within the tank.
- Increases the tank effective capacity as the minimum draw down level is lower than with conventional side entry outlet pipes.



**Manufactured in accordance with BSEN13280:2001**

**Sprinkler systems are an integral part of good fire safety management**

**Available up to a capacity of 1300m<sup>3</sup>**

## RAINWATER HARVESTING TANKS

Rainwater Harvesting is becoming a popular concept within the UK to alleviate water shortages and to aid in reducing potable water consumption to 50 litres per person per day to achieve BREAM ratings. Many commercial premises have also adopted the rainwater harvesting policy into their sustainable drainage program to reduce surface water run by reusing it for non-potable applications. Installing a rainwater harvesting system also reduces water costs for domestic and commercial premises.

Rainwater Harvesting is capturing the rainwater from a roof area and reusing it for applications such as toilets, process water, garden irrigation etc. Water is saved in a tank located underground or aboveground.

Our sectional storage tanks are an ideal choice to use as a holding tank and particularly suitable in premises retrofitting rainwater harvesting systems. We have designed a system incorporating our sectional tank along with a filter, calmed inlet, floating suction filter, pump, overflow siphon and water back up system that complies with BS8515. A cylindrical tank for underground installation option is also available.

**There are 3 types of systems available:**

### Gravity System

Rainwater enters the tank and services by gravity. There is no pump in this system. It is mainly used for garden watering.

### Pumped/ Pressurised System

Rainwater enters the holding tank by gravity and is pumped to the services.

### Attic Tank System

Rainwater enters the holding tank by gravity and is pumped to a tank in the attic and continues from there by gravity to the services.



Rainwater Harvesting Tank

## SITE REQUIREMENTS

The following must be complied with prior to assembly of the tank to ensure a long life span. Base and access requirements differ slightly for the various tank designs. Detailed requirements are available from our sales department for every tank size.

### Base Requirements

#### Standard Sectional, L-Shaped, TIF and IF Tanks

The tank design will determine which base panel option(s) may be used. The base panel will then determine which type of foundation/plinth option are suitable. If in doubt, speak with our sales team.

#### T1 DESIGN

Tanks from 1 to 3m and 1.2 to 2.4m

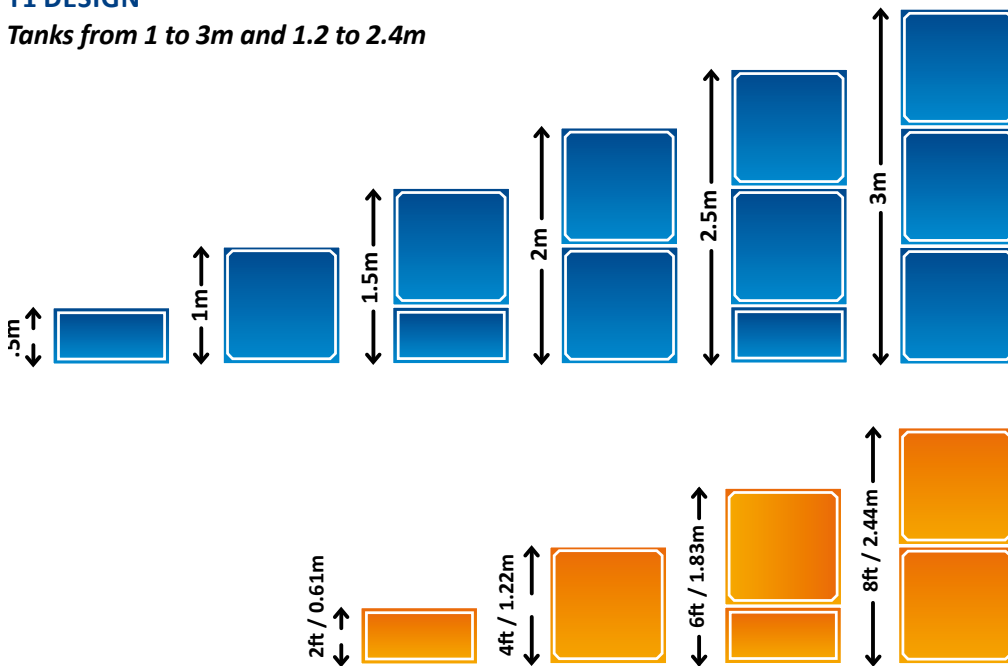

#### T2 DESIGN

Tanks from 3.5 to 4m

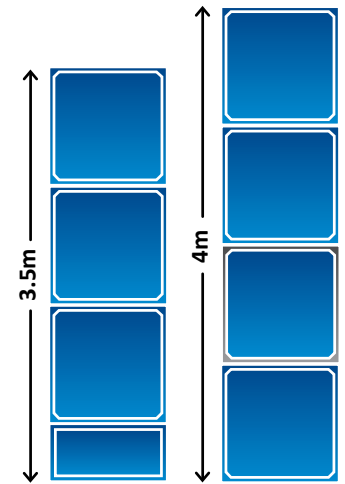

Base Type	T1 Design	T2 Design	TIF	IF	L Shaped
Flat internally flanged	✓	✓	✓	✓	✓
Half span internally flanged	✓	✓	✓	✓	✓
Half span externally flanged truncated	✓	✓	✗	✓	✓
Half span externally flanged self draining	✓	✓	✗	✓	✓
*Full span externally flanged truncated	✓	✗	✗	✓	✓
*Full span externally flanged self draining**	✓	✗	✗	✓	✓

\* Please allow a minimum clearance of 600mm under the tank

\*\* Maximum height of 2m



**Foundation/Plinth Options:**

The foundation should be flat, level, free from local irregularities and not vary more than 2mm in any 1 metre or a total of 6mm in any 6metres measured laterally or diagonally. It should extend at least 150mm beyond the dimension of the tank.

**Nominal Capacity Chart**

Length	Width	1m High	1.5m High	2m High	2.5m High	3m High	3.5m High	4m High
1m	1m	1000 L	1500 L	2000 L	2500 L	3000 L	3500 L	4000 L
		220 G	330 G	440 G	550 G	660 G	770 G	880 G
1.5m	1m	1500 L	2250 L	3000 L	3750 L	4500 L	5250 L	6000 L
		330 G	495 G	660 G	825 G	990 G	1160 G	1330 G
2m	1m	2000 L	3000 L	4000 L	5000 L	6000 L	7000 L	8000 L
		440 G	660 G	880 G	1100 G	1330 G	1555 G	1760 G
2.5m	1m	2500 L	3750 L	5000 L	6250 L	7500 L	8750 L	10,000 L
		550 G	825 G	1100 G	1375 G	1650 G	1940 G	2220 G
3m	1m	3000 L	4500 L	6000 L	7500 L	9000 L	10500 L	12000 L
		660 G	990 G	1320 G	1650 G	1980 G	2330 G	2640 G
3.5m	1m	3500 L	5250 L	7000 L	8750 L	10500 L	12250 L	14000 L
		770 G	1160 G	1555 G	1940 G	2330 G	2720 G	3110 G
4m	1m	4000 L	6000 L	8000 L	10000 L	12000 L	14000 L	16000 L
		880 G	1320 G	1760 G	2200 G	2640 G	3110 G	3550 G
2m	1.5m	3000 L	4500 L	6000 L	7500 L	9000 L	10500 L	12000 L
		660 G	990 G	1320 G	1650 G	1980 G	2330 G	2640 G
2.5m	1.5m	3750 L	5625 L	7500 L	9375 L	11250 L	13125 L	15000 L
		825 G	1238 G	1650 G	2063 G	2475 G	2910 G	3330 G
3m	1.5m	4500 L	6750 L	9000 L	11250 L	13500 L	15750 L	18000 L
		990 G	1485 G	1980 G	2475 G	2970 G	3500 G	4000 G
2.5m	2m	5000 L	7500 L	10000 L	12500 L	15000 L	17500 L	20000 L
		1100 G	1650 G	2200 G	2750 G	3300 G	3880 G	4440 G
3m	2m	6000 L	9000 L	12000 L	15000 L	18000 L	21000 L	24000 L
		1320 G	1980 G	2640 G	3300 G	3960 G	4660 G	5330 G
4m	2m	8000 L	12000 L	16000 L	20000 L	24000 L	28000 L	32000 L
		1760 G	2640 G	3520 G	4400 G	5280 G	6220 G	7110 G
5m	2m	10000 L	15000 L	20000 L	25000 L	30000 L	35000 L	40000 L
		2200 G	3300 G	4400 G	5500 G	6600 G	7770 G	8880 G
6m	2m	12000 L	18000 L	24000 L	30000 L	36000 L	42000 L	48000 L
		2640 G	3960 G	5280 G	6600 G	7920 G	9330 G	10660 G
3m	3m	9000 L	13500 L	18000 L	22500 L	27000 L	31500 L	36000 L
		1980 G	2970 G	3960 G	4950 G	5940 G	7000 G	8000 G
4m	3m	12000 L	18000 L	24000 L	30000 L	36000 L	42000 L	48000 L
		2640 G	3960 G	5280 G	6600 G	7920 G	9330 G	10660 G
5m	3m	15000 L	22500 L	30000 L	37500 L	45000 L	52500 L	60000 L
		3300 G	4950 G	6600 G	8250 G	9900 G	11600 G	13300 G
6m	3m	18000 L	27000 L	36000 L	45000 L	54000 L	63000 L	72000 L
		3960 G	5940 G	7920 G	9900 G	11880 G	14000 G	16000 G
4m	4m	16000 L	24000 L	32000 L	40000 L	48000 L	56000 L	64000 L
		3520 G	5280 G	7040 G	8800 G	10560 G	12440 G	14220 G
5m	4m	20000 L	30000 L	40000 L	50000 L	60000 L	70000 L	80000 L
		4400 G	6600 G	8800 G	11000 G	13200 G	15550 G	17770 G
6m	4m	24000 L	36000 L	48000 L	60000 L	72000 L	84000 L	96000 L
		5280 G	7920 G	10560 G	13200 G	15840 G	18660 G	21330 G
7m	4m	28000 L	42000 L	56000 L	70000 L	84000 L	98000 L	112000 L
		6160 G	9240 G	12320 G	15400 G	18480 G	21770 G	24880 G
5m	5m	25000 L	37500 L	50000 L	62500 L	75000 L	87500 L	100000 L
		5500 G	8250 G	11000 G	13750 G	16500 G	19440 G	22220 G

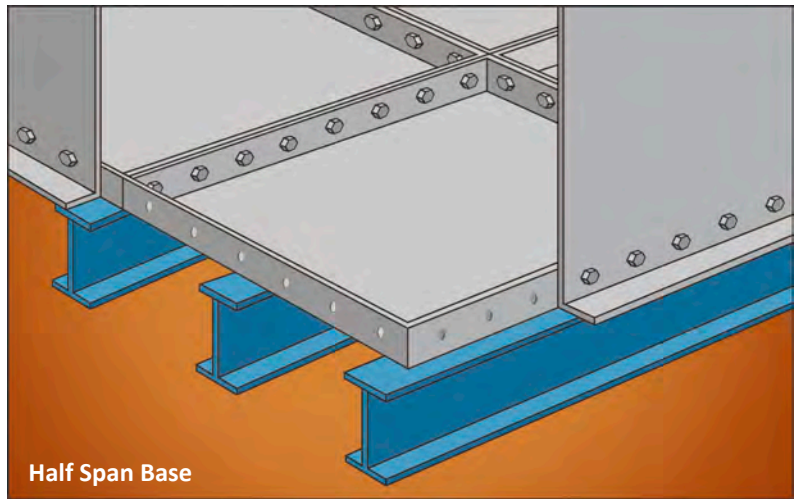
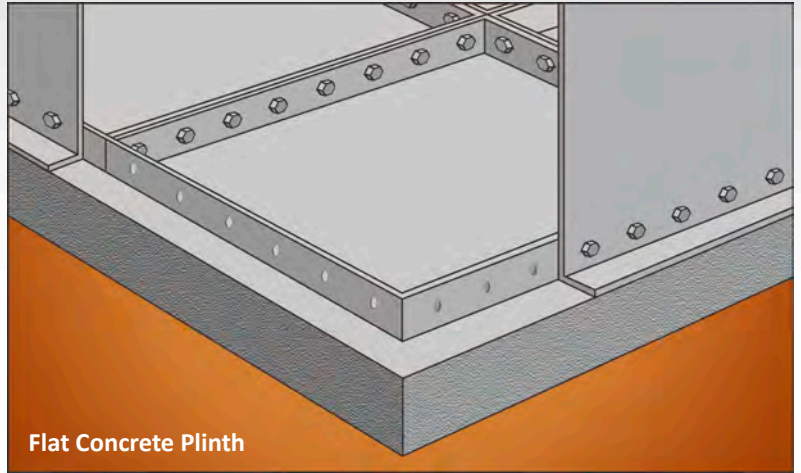

Supports must be level and positioned at 500mm centres for metric panels and 610mm centres required for externally flanged imperial panels and 406mm centres for internally flanged imperial panels.

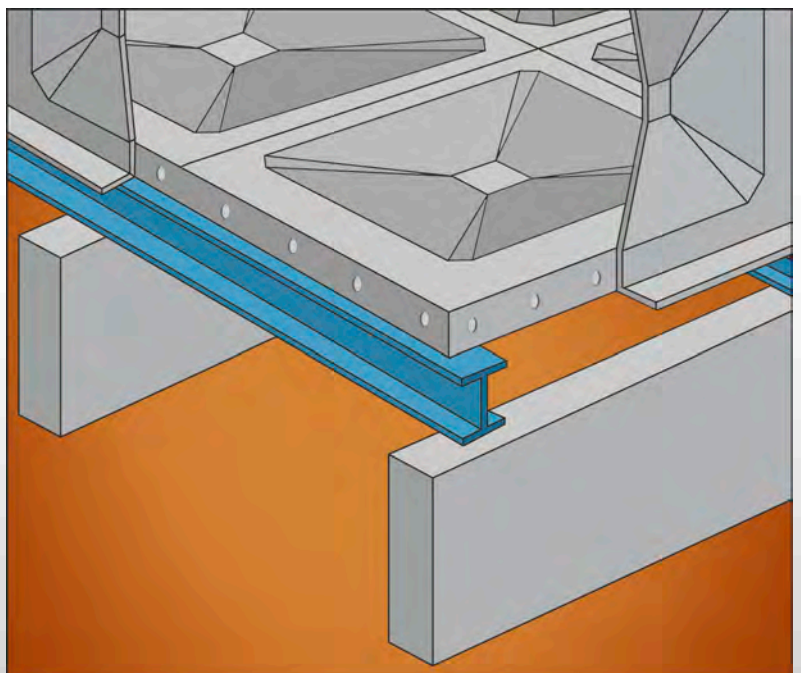

**Full Span Base**

Supports must be level and positioned at 1000mm centres for metric panels and 1220mm centres for imperial panels. Bearer surface min. 75mm - max. 150mm

*\*If base is externally flanged, please allow a clearance of 600mm under the tank  
If your requirements are not catered for in this brochure, please contact our Technical Department.*

**LPCB Fire Protection Tanks**

Plinth and access requirements are vary for each tank. Please contact our technical service department, where a detailed drawing is available.

**ACCESS REQUIREMENTS**

T1 Design  $\longleftrightarrow$  T2 Design  $\longleftrightarrow$

Plan View

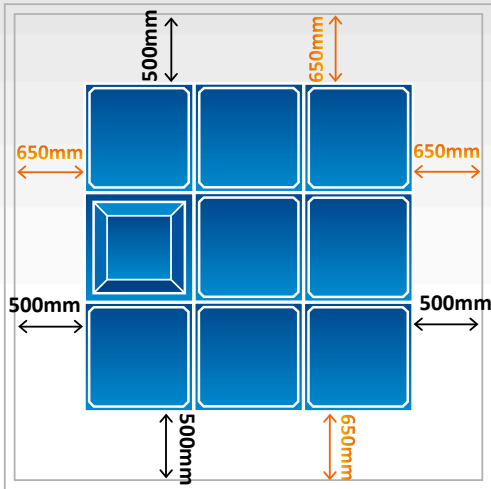

TIF Tank - Plan

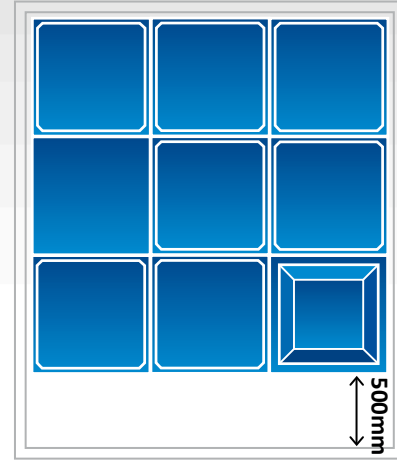

**Note:** If space around the tank is less than 800mm and the tank is more than 2 metres above ground, then the clients will need to supply fixed scaffold for installation.

Side Elevation - Internally Flanged Base

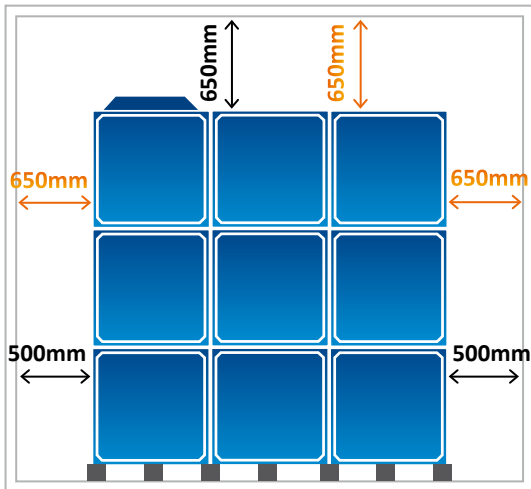

IF Tank - Plan

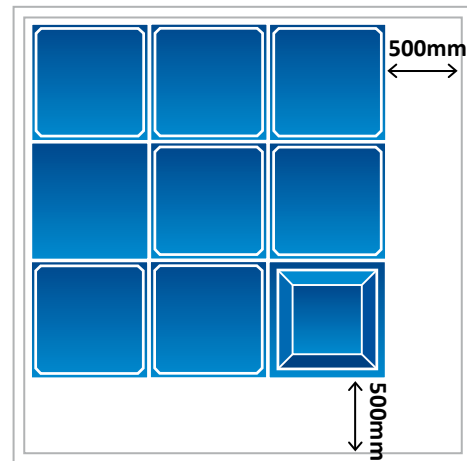

Side Elevation - Externally Flanged Base

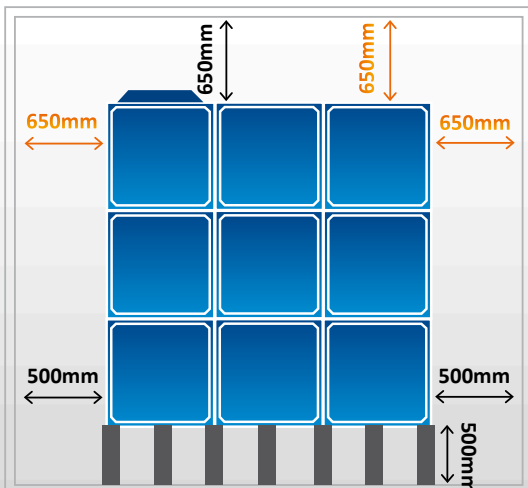

TIF & IF Tanks - Side Elevation

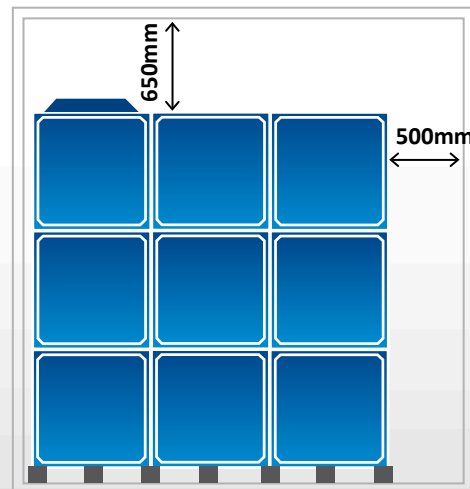



## TANK MAINTENANCE

Dewey Waters offer a complete maintenance package to protect your tank investments. Preventative maintenance and timely inspections will help prolong the life of your tanks. We have the established ability to perform all of the necessary inspections and maintenance tasks without the need for expensive outside contractors. By inspecting the tanks on a regular basis we can solve small problems before they escalate to become bigger problems.

### Benefits of adopting an ongoing Maintenance Program with Dewey Waters Ltd:

- Tanks are continually examined and all aspects of maintenance are dealt with in a preventive mode.
- All aspects of maintenance needed to ensure the tank can be utilized indefinitely.
- Assures tank owners that conditions on the interior are properly maintained, and that the water is being stored in a manner that does not affect its quality.
- Assures tank owners that the tank remains in compliance with British Standard.
- Provides annual documentation and reports that are required by Local Authorities.
- Provides immediate response for unexpected emergencies that may occur.







Quality Systems Certificate No: 135  
Assessed to ISO 9001:2008



Full WRC Type 'AB' Air Gap Approval,  
GRP Sprinkler Suction,  
Sectional & One Piece Cisterns



Association of Tank  
and Cistern Manufacturers

**Dewey Waters Ltd**

Heritage Works, Winterstoke Road, Weston-Super-Mare, BS24 9AN • Tel: +44 (0) 1934 421477 • Fax: +44 (0) 1934 421488

Email: [sales@deweywaters.co.uk](mailto:sales@deweywaters.co.uk) • Web: [www.deweywaters.co.uk](http://www.deweywaters.co.uk)



**TRICEL**  
GENERATIONS OF INNOVATION

*In accordance with our normal policy of product development these specifications are subject to change without notice.*